



MCHybrid 200

The best of dosing and blending in one system

Including real time throughput measurement for extrusion

The MCHybrid 200* is a unique dosing concept that combines two technologies into one system: batch blending and in-line dosing.

The main materials or regrinds are mixed in an extreme compact gravimetric batch blender. Because the system only blends the main materials, the blending speed is high and therefore the batch blender remains small.

The additives are dosed gravimetrically in-line, directly on the throat of the injection molding machine or extruder.

By using these two blending and dosing technologies in one machine, you are able to control the main materials in any given ratio and at the same time dose additives at low percentages with unequalled accuracy.

The MCHybrid 200 is available for capacities up to 1,000 kg/h with 2-8 blending components and up to maximum 14 in-line dosing components.

If requested, the blender itself can also be used without the in-line dosing units. In that case the capacity and the accuracy will reduce compared to the MCHybrid concept.

* patent pending

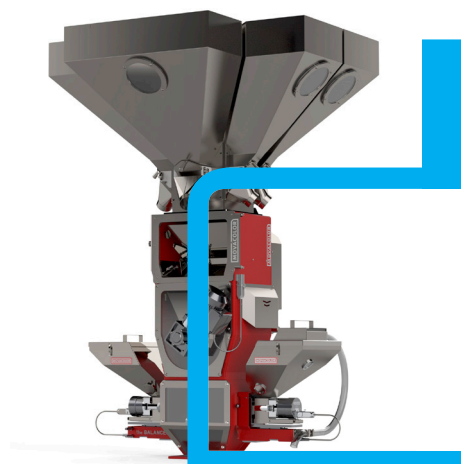

Features

- Fully gravimetric
- 8" full color touch screen with user-friendly interface
- Able to store up to 1,000 recipes
- Capacity max. 1,000 kg/h
- 2-8 main components and max. 14 in-line additives
- Extremely compact
- Able to handle powders and liquids in one system
- Quick and easy change of additives
- Option of weighing mixing bin (real time throughput measurement)

Compact design

Because only the main components are blended gravimetrically, a high capacity can be achieved with a relatively small batch blender.

Different materials handled

The in-line dosing of the additives allows easy color change plus the option to use additives that cannot be handled with a regular batch blender, such as powders or liquids.



Extremely accurate

As the additives are dosed in-line, no segregation can take place which prevents color variations.

MOVACOLOR LEADING INNOVATOR IN DOSING TECHNOLOGY

For almost three decades, Movacolor has been dedicated to coloring the world in a sustainable way. We do so by developing high-precision gravimetric and volumetric dosing systems. Our knowledge, experience and innovation capabilities are invested in a comprehensive portfolio of user-friendly products. These work easily and effortlessly together in advanced systems that conserve additives, increase production flexibility and deliver excellent results.

MCHybrid 200

Technical specifications

CAPACITY

Maximum 1,000 kg/h*

APPLICATIONS

Injection molding and extrusion
Option weighing mixing chamber (real time capacity measurement)

NUMBER OF COMPONENTS

- Maximum 8 main components
- Maximum 14 additives in-line
- 100% draining main hoppers
- Removable weighing bin and mixing chamber

COMMUNICATION

Modbus TCP/IP, Profibus**, Profinet**

DATA STORAGE

Internal memory (static changes), MCSmart data logging software (dynamic changes), 1,000 recipes storage function

POWER SUPPLY

110-250 VAC, 50/60 Hz. By integrated automatic voltage selector

POWER CONSUMPTION

700 Watt for 6 components

LANGUAGES

English, German, Dutch, French, Hebrew, Turkish, Chinese, Thai, Japanese, Russian, Italian, Czech, Portuguese, Spanish, Indonesian, Polish, Korean, Hungarian, Swedish, Romanian***

OPERATION

8" full color touch screen display

INPUT SIGNALS

Start input: potential free, 24 VDC or extruder tacho (0-30 VDC)

OUTPUT SIGNALS

Alarm, warning, run, valve (for hopper loader control), 2x0-10 VDC** or 4-20 mA**

* measured with a bulk density of 0.8 kg/dm³.
Capacity depends on material characteristics and number of blending components.

** optional

*** additional languages on request



Exploded view

- 1 Hopper
- 2 Dosing valve
- 3 Controller
- 4 Door
- 5 Body
- 6 Mixing chamber
- 7 Weighing bin
- 8 Hopper bracket

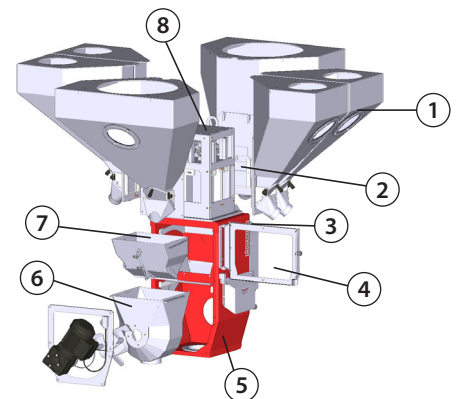

Dimensions

