



## DDM 30-G

Gravimetric Desiccant Dryer Mobile  
Drying of free-flowing granular plastic materials



# Desiccant Dryer Mobile - DDM 30-G

## Introduction

Labotek's brand new mobile desiccant dryer, the DDM 30-G, is designed for the continuous drying of free-flowing plastic raw materials in granulate form.

The DDM 30-G is a breakthrough in adaptive drying for mobile dryers as a complete desiccant drying and integrated dry air conveying system to the processing machine, based on a proven, reliable and energy-saving design.

The standard temperature range is 60 to 140°C with a preset deviation of +/- 2°C. A HT (High Temperature) model is also available with a temperature range of 60 to 180°C.

Owing to the extremely accurate temperature control and a dew point of <-50°C, a final moisture content of less than 0.02% can be achieved (HT model 0.002%). The dryer is equipped with 3 modes of duty cycle for the regeneration circuit, and the inbuilt material database enables the use of a predefined duty cycle for each raw material type.

## DDM 30-G standard execution

- Built-in load cell for adaptive drying
- Material database
- 7" color touch screen
- OPC-UA ready
- Small footprint of only 0.46 m<sup>2</sup>
- AISI 304 stainless steel interior and exterior
- Drying hopper capacities of 30 litres
- Electrical 3-phase power supply
- Unique dry air conveying system to process machine
- Built-in 3-phase conveying system to dryer (SVR)
- Dew point connection gate
- A separate over-temperature thermostat
- Comprehensive 3-year warranty, excluding wear parts

## Touch Screen Control

DDM is operated via the microprocessor-based, 7" color touch screen control. The touch screen is menu-driven, using basic symbols and enabling easy operator interface. Furthermore, the control is fully OPC UA ready and features shortcuts to the most basic functions, i.e. throughput settings, drying temperature, duty cycle, drying time, weekly start/stop timer, and much more.



## Gravi-Dryer®

Labotek's renowned Gravi-Dryer® functionality is integrated with the DDM 30-G, as the inbuilt load cell system will provide adaptive drying according to actual material consumption, and pre-drying of the raw material will happen via the "Ramp Up" principle. If capacity demand increases/decreases, the dryer will automatically adjust the fill level in the drying hopper to suit the current requirement. "Ramp Down" is used to lower volume at production end.

## LESS - system

Labotek Energy Saving System has been designed to achieve energy savings of the drying air that is fed to the drying hopper, as well as providing protection against over-drying. The LESS system in DDM operates using a relative lowering of drying temperature after reaching the set value. Temperature reduction will begin when the material has been dried.

## Material database

The menu-driven 7" color touch screen control includes a material database, where 100 raw materials may be stored. The database includes all necessary data to ensure optimal conditions for the material to be dried. Values are editable for under administrator login.





*A breakthrough in adaptive drying for mobile dryers as a complete desiccant drying and integrated dry air conveying system, based on a proven, reliable and energy-saving design.*



## Drying

The dry air blower (2) circulates the drying air in a closed system. The air is dried in one of the two desiccant beds (4), and the dew-point temperature is lowered to approx. From -40 to -60°C depending on duty cycle setting. The dry air heating element (23) is used to heat the drying air to the required temperature before, via the air separator (6), it is distributed in the drying hopper DH (1). Actual hourly throughput is adjustable via the load cell system (22).

After the drying air has heated the raw material and transformed the moisture into water vapor, it is led back through the dust filter (8) to the blower (2). The humid air is cooled in the structural frame (12) of the machine just before it is led to one of the desiccant beds (4) which will adsorb the humidity. In HT units the air is cooled through the cooler (12).

## Regeneration

The DDM dryer has two desiccant beds (4) with molecular sieves for dehumidification of the drying air. One of the beds is always operative in the drying cycle whereas the other is either regenerating in the regeneration cycle or, when fully regenerated, in standby mode.

Regeneration occurs when hot air passes through the desiccant bed (4).

The regeneration blower (9) takes in ambient air through the intake filter (10) and sends it to the regeneration heating element (5) where the air temperature is increased to approx. 110-130°C, depending on the duty cycle setting. The moisture adsorbed in the desiccant bed is evaporated and forced into the ambient air in the form of water vapour.

In the last phase of the regeneration cycle, the regeneration heating element (5) is disconnected and as the position of the regeneration valve (11) changes, the air is re-circulated in a closed system. This is done to cool the molecular sieve through a cooling frame (14) and to lower the dew point temperature to approx. -40 to -60°C. In HT units the cooling frame (14) is cooled by water.

Two automatic, double-acting valve units (13) are placed at the inlet and the outlet of the desiccant beds ensuring that one of the desiccant beds is always operative in the drying cycle and the other in the regeneration cycle. The time between regenerations is variable and calculated according to moisture pick-up, monitored in microprocessor control and regeneration sensor (19).

## Conveying

Raw material is fed automatically into the machine hopper proportional to the consumption of the processing machine.

The principle is that part of the blower (2) drying air is bypassed and sent to the injector (7) whereby the dried raw material is sucked from the drying hopper utilising the injector effect. The injector is adjustable. It can be adjusted to match size and shape of the granular material. Consequently, most types of regrind can be conveyed.

The raw material is blown from the injector (7) to the air separator (15) which is either located directly on the machine hopper or fitted on the barrel inlet using a special intermediate flange. Conveying is initiated by the slide valve (16) inside the air separator. Conveying air is now fed from the material hose (17) into the return air hose (18). Conveying stops automatically when the machine hopper has been fully loaded, thus blocking the air passage between (17) and (18). Conveying into drying hopper is using a dry air blower (2) to generate vacuum, enabled via vacuum valves (3).

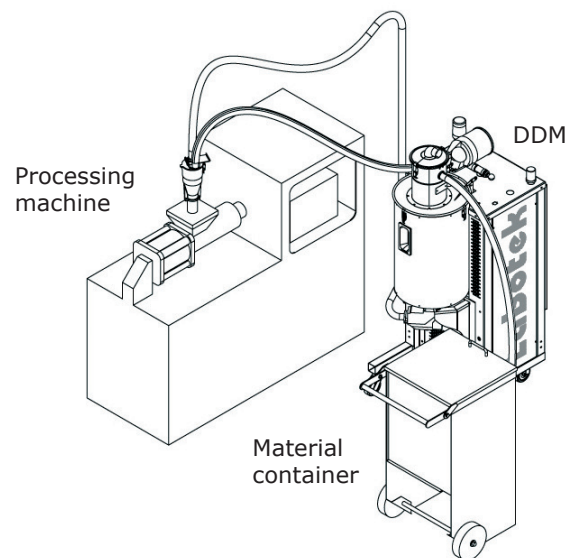

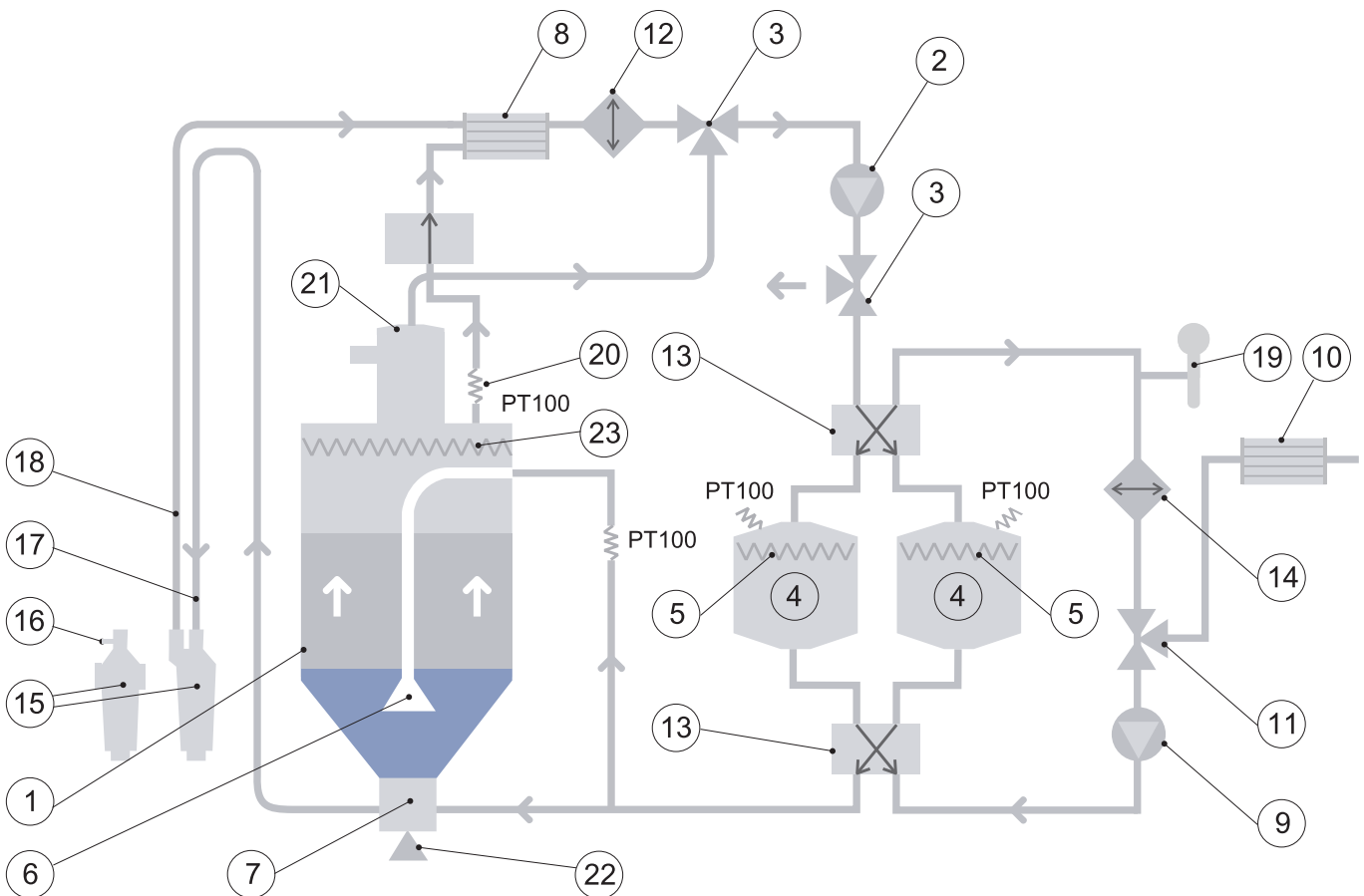
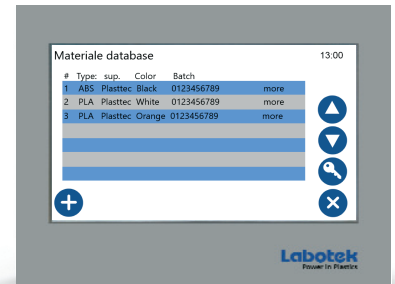
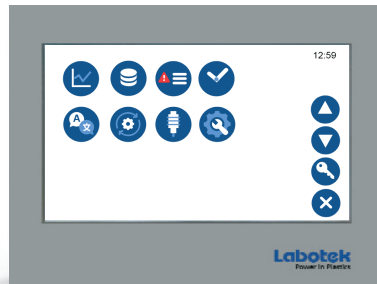
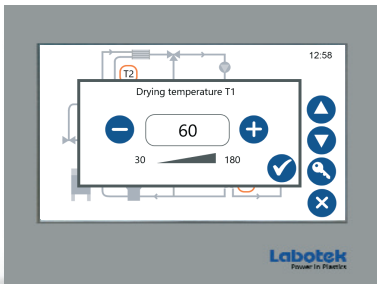
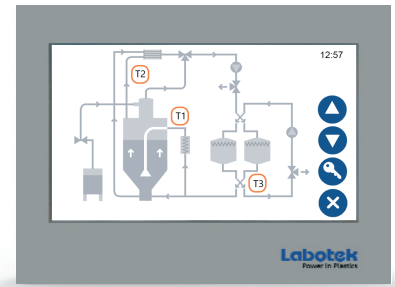
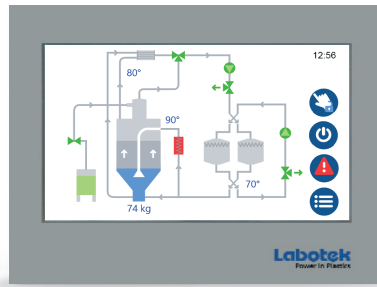
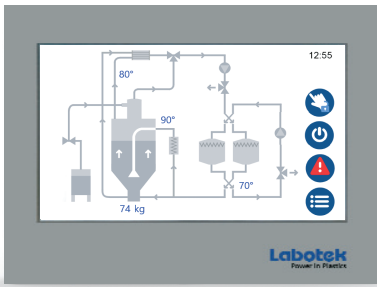

- |                           |                    |                            |
|---------------------------|--------------------|----------------------------|
| 1. Drying Hopper          | 9. Reg. blower     | 17. Mater. Hose            |
| 2. Dryer/Conveying blower | 10. Reg. filter    | 18. Mater. Hose            |
| 3. Vacuum valve           | 11. Reg. valve     | 19. Regeneration sensor    |
| 4. Desiccant bed          | 12. Cooler         | 20. Sensor PT100           |
| 5. Heating element        | 13. Doubling valve | 21. SVR 1,5                |
| 6. Air separator          | 14. Reg. cooler    | 22. Load cell              |
| 7. Injector               | 15. Air separator  | 23. Heating element drying |
| 8. Dust filter            |                    |                            |

## Capacity table

Raw material		Recommended dry time [h]	Recommended drying temp. °C	Drying capacity kg/h at bulk density 0.6
				DDM 30-G
ABS	Acrylonitrile butadiene styrene	2-3	80	9-6
PA	Polyamide 6/6.6/10	3	75-80	6
PA	Polyamide 11/12	4	75-80	4.5
PBT	Polybutylene terephthalate	3	120	6
PC	Polycarbonate	2-3	120	9-6
PE	Polyethylene	1-2	80-90	18-9
PE	Polyethylene, black	3-4	90	6-4.5
PEC	Polyestere carbonate	4-5	130	4.5-3.5
PEEK	Polyaryletherketone	2-3	150	9-6
PEI	Polyetherimide	3-4	150	6-4.5
PET	Polyethylene terephthalate	4-6	170-180*	4.5-3
PETG	Polyethylene terephthalate glycol	4	66	4.5
PETP	Thermoplastic polyesters	2-3	120	9-6
PI	Polyimide	2-3	120	9-6
PMMA	Methylmethacrylate polymer	2-3	80	9-6
POM	Polyacetal	2-3	100	9-6
PP	Polypropylene	1-2	80-90	18-9
PPO	Polyphenylene oxide	2	110	9
PPS	Polyphenylene sulphide	3-4	150*	6-4.5
PPSU	Polyether sulfone	3-4	120	6-4.5
PS	Polystyrene	1-2	80	18-9
PSU	Polysulfone	2-3	130	9-6
PUR	Polyurethane	2-3	90-100	9-6
PVC	Polyvinyl chloride	1	70	18-9
SAN	Styrene acrylonitrile	2-3	80	9-6
SB	Styrene butadiene (high impact)	1-2	80	18-9
TPE	Polyester elastomer	2-3	110	9-6
TPR	Thermoplastic rubber	3	75	6

\*) = HT version

The above capacity table states recommended values only, based on the drying of the specific materials down to a residual moisture content of 0.02% which, however, will vary depending on the type of material. The capacities are based on a general bulk density of 0.6 with the exception of PE and PETG for which a bulk density of 0.55 and 0.85 respectively forms basis.

Pos.	Description	LT no.
1	Cyclone, dust separation, with plastic container	208861
2	Warning lamp, DDM, flash lamp, yellow/blinking, 24 V AC	207772
2	Warning lamp, DDM, flash lamp, yellow/blinking/sound, 24 V AC	207868
3	Flange for air separator Ø 50 mm, DDM	202500
4	By-Pass assembly for DDM	208460
-	Tropical execution	208995
-	OPC UA license	209039

## Options

The DDM is prepared for a number of options to ensure optimal treatment of the material being processed.

Tropical execution DDM for high ambient conditions (up to 45°C with 90% RH).

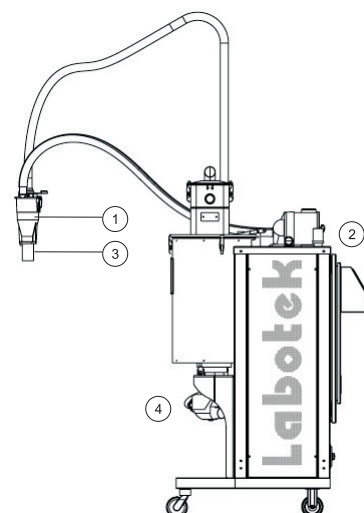

# Technical Data

DDM Type	DDM 30-G
Supply Voltage	380-480 V 50 / 60 Hz
Installed Power, kW	4.3
Blower motor, drying - 3 Phase 50 / 60 Hz, kW	0.4 / 0.48
Air volume m <sup>3</sup> /h - 50 / 60 Hz	18 / 22
Water column [mm]	1400 / 1680
Blower motor, regeneration - 3 Phase 50 / 60 Hz, kW	0.2 / 0.24
Dew point, temp.	> -40°C
Heating element, Drying - kW	1.5
Heating element, Drying HT version - kW	1.5
Heating element, Regeneration - kW	2.2
Cooling water requirement - HT version	
Noise level (dBA)	63
Drying Hopper, sizes (litre)	30
Desiccant beds	2
Conveying hose, inner Ø [mm] / length [m]	32 / 2.5
Return air hose, inner Ø [mm] / length [m]	32 / 3
Telescopic suction probe, Ø [mm]	32
Vacuum Receiver	SVR 1,5
Air separator	1
Connecting cable [m]	3
Net weight [kg] / Shipping weight [kg]	170 / 190
Shipping volume [m <sup>3</sup> ]	1.5
Shipping dimensions [mm]	L 1200 - W 770 H 1550

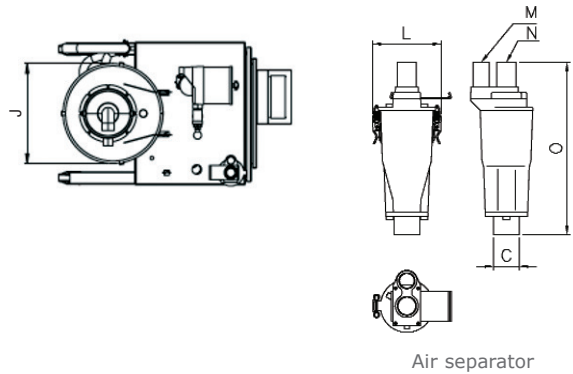
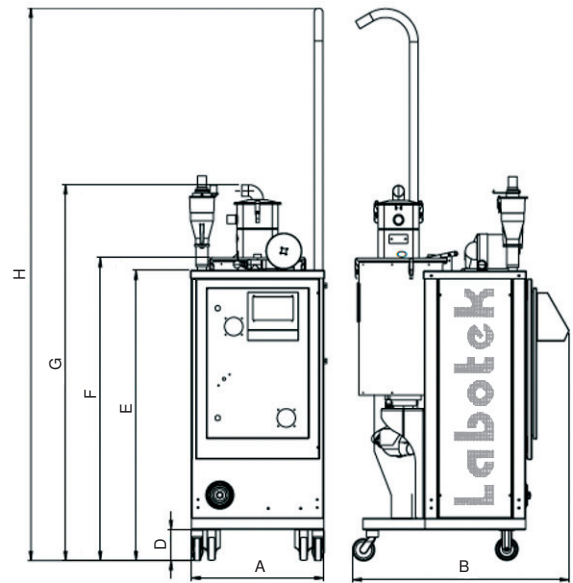

## Dimensions

	A	B	C	D	E	F	G	H	J	L	M	N	O
DDM 30-G	580	958	Ø 51	137	1270	1325	4367	411	136	136	Ø 32	Ø 38	440

All measurements are in mm

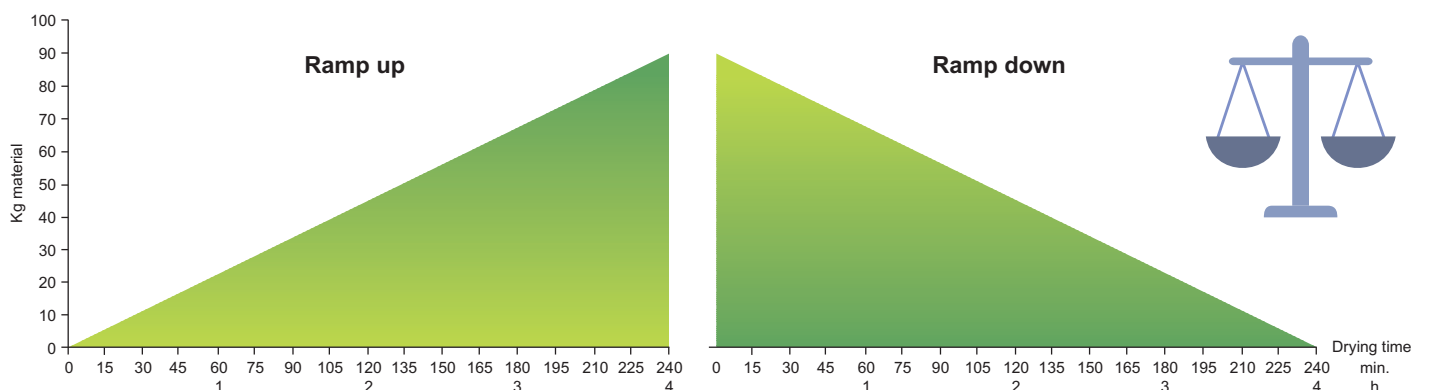

**3 years  
warranty**

Labotek offers 3 years warranty  
- excluding wear parts

**Labotek A/S**  
Stroebjergvej 29  
DK-3600 Frederikssund

+45 4821 8411  
info@labotek.dk  
www.labotek.com

Representative